

AERON

This inlet offers the best features required in the market today. With a middle hinged inner valve the air also flows underneath the valve when it is 30% opened. The inner valve is equipped with seals on the sides and top, to prevent air leakage. The house also has a seal in the bottom for perfect closure when the valve is shut. Newly designed clock springs on each side of the valve help open the inlet and keep control.

The shape of the house, designed with airflow simulation software, guarantees optimal performance. The combination of materials and air seals help to make this inlet suitable in many different climates. The W-shape of the inner valve helps to create jets which give perfect control during minimum ventilation. During maximum ventilation air is also guided downwards to the animals to deliver a cooling effect.

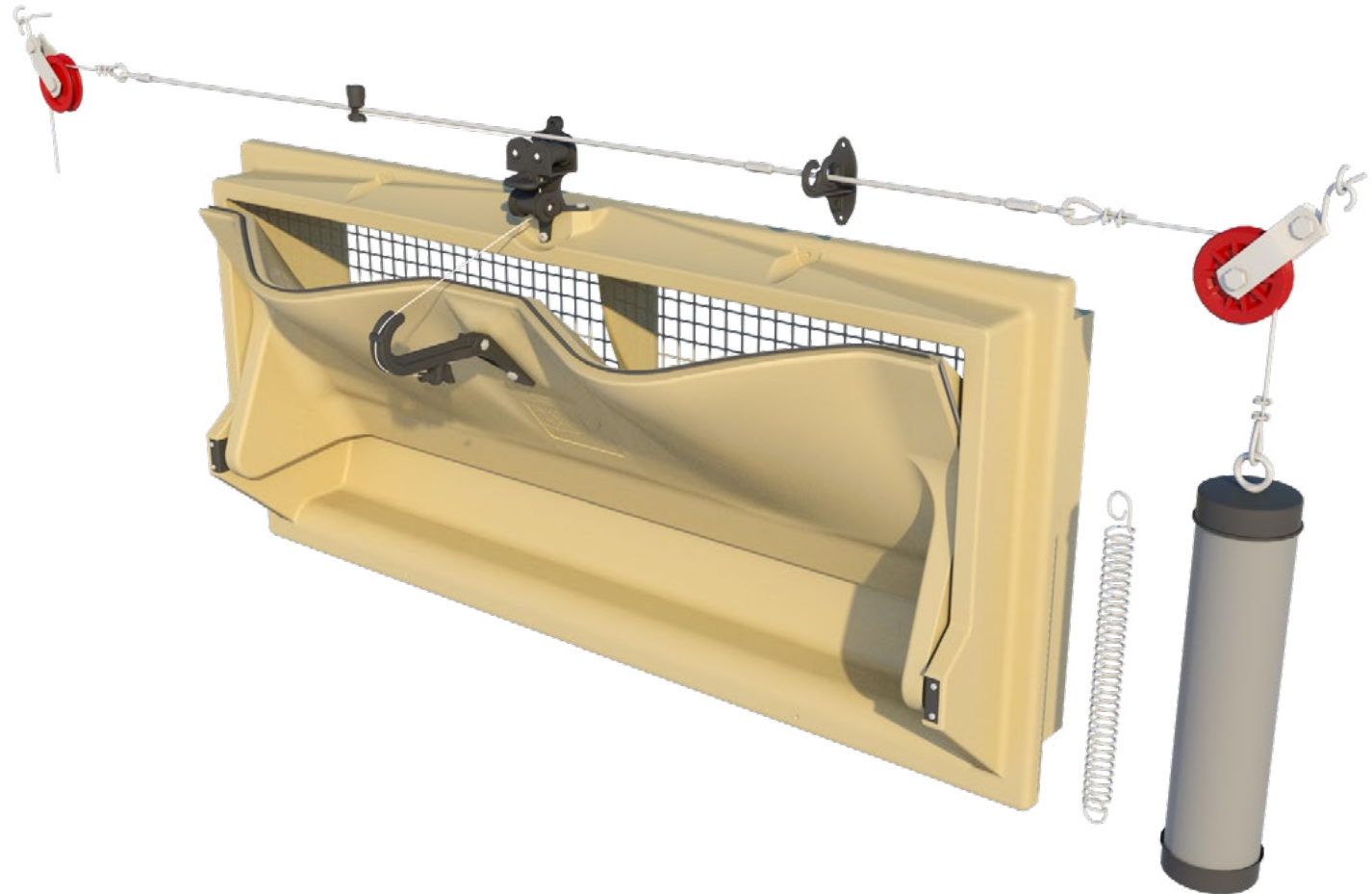

INFO

DATASHEET

ASSEMBLY

MOUNTING

WORKING

MAINTENANCE



AERON DATASHEET



CAPACITY

Model	m ³ /h @ 10 Pa	m ³ /h @ 20 Pa	m ³ /h @ 40 Pa
Aeron	3100	4400	6250
	cfm @ 0.05 inH ₂ O	cfm @ 0.1 inH ₂ O	cfm @ 0.15 inH ₂ O
	2040	2890	3552

INFORMATION

Run	55 cm / 21.7 Inch
Force	4.5 kg / 44 Newton
Number / pallet (1,30 x 1,00 x 2,60m / 51,2 x 39 x 102inch)	24
Weight / per inlet	5,3 kg / 11.7 lbs
Volume / per box	12
Arm position	2

OPTIONAL ACCESSORIES

TPI-120	Wire mesh synthetic
TPI-204c	Connection set
TPI-423	Pulley Unit + Closing Catch

AIR FLOW

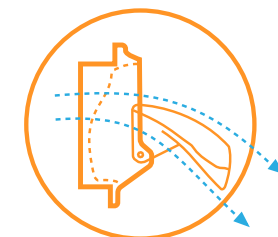

INFO

DATASHEET

ASSEMBLY

MOUNTING

WORKING

MAINTENANCE



TPI-204C

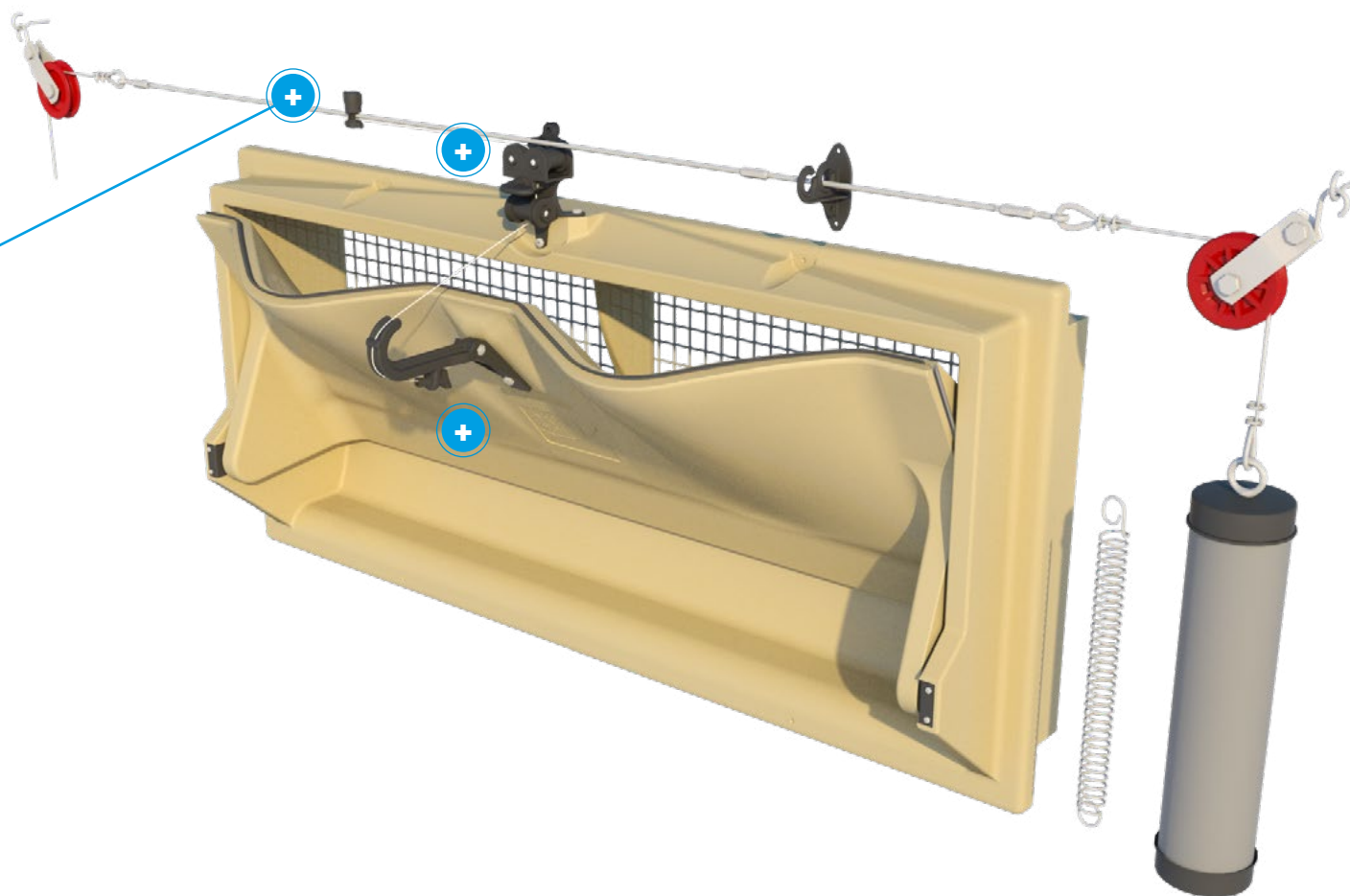

INFO

DATASHEET

ASSEMBLY

MOUNTING

WORKING

MAINTENANCE

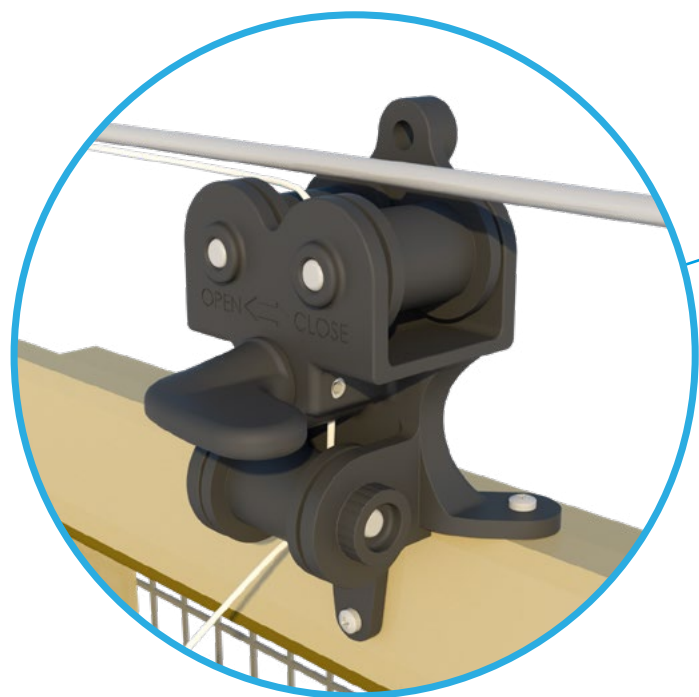

TPI-423

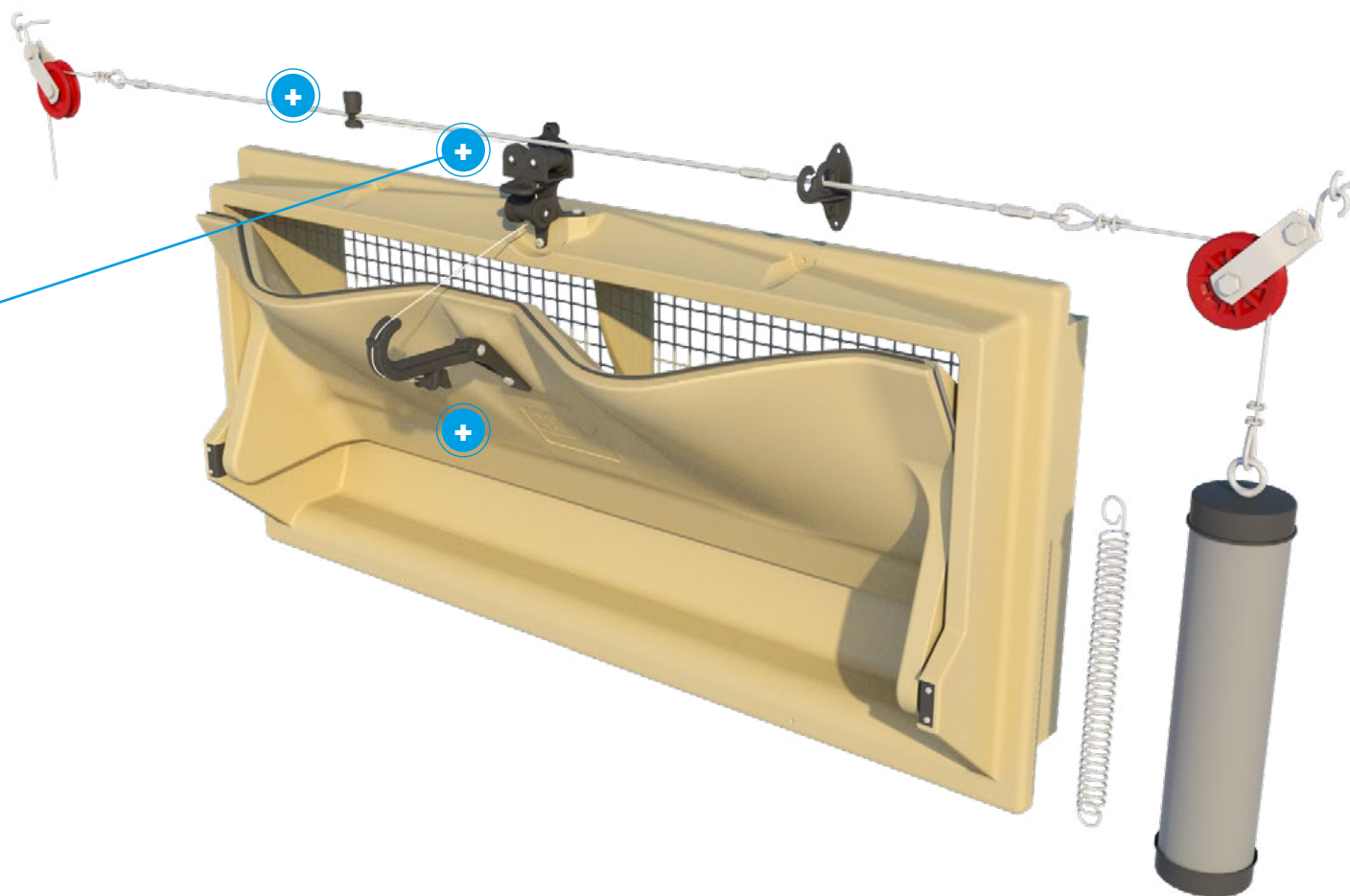

[INFO](#)

[DATASHEET](#)

[ASSEMBLY](#)

[MOUNTING](#)

[WORKING](#)

[MAINTENANCE](#)



Arm angle position : 2

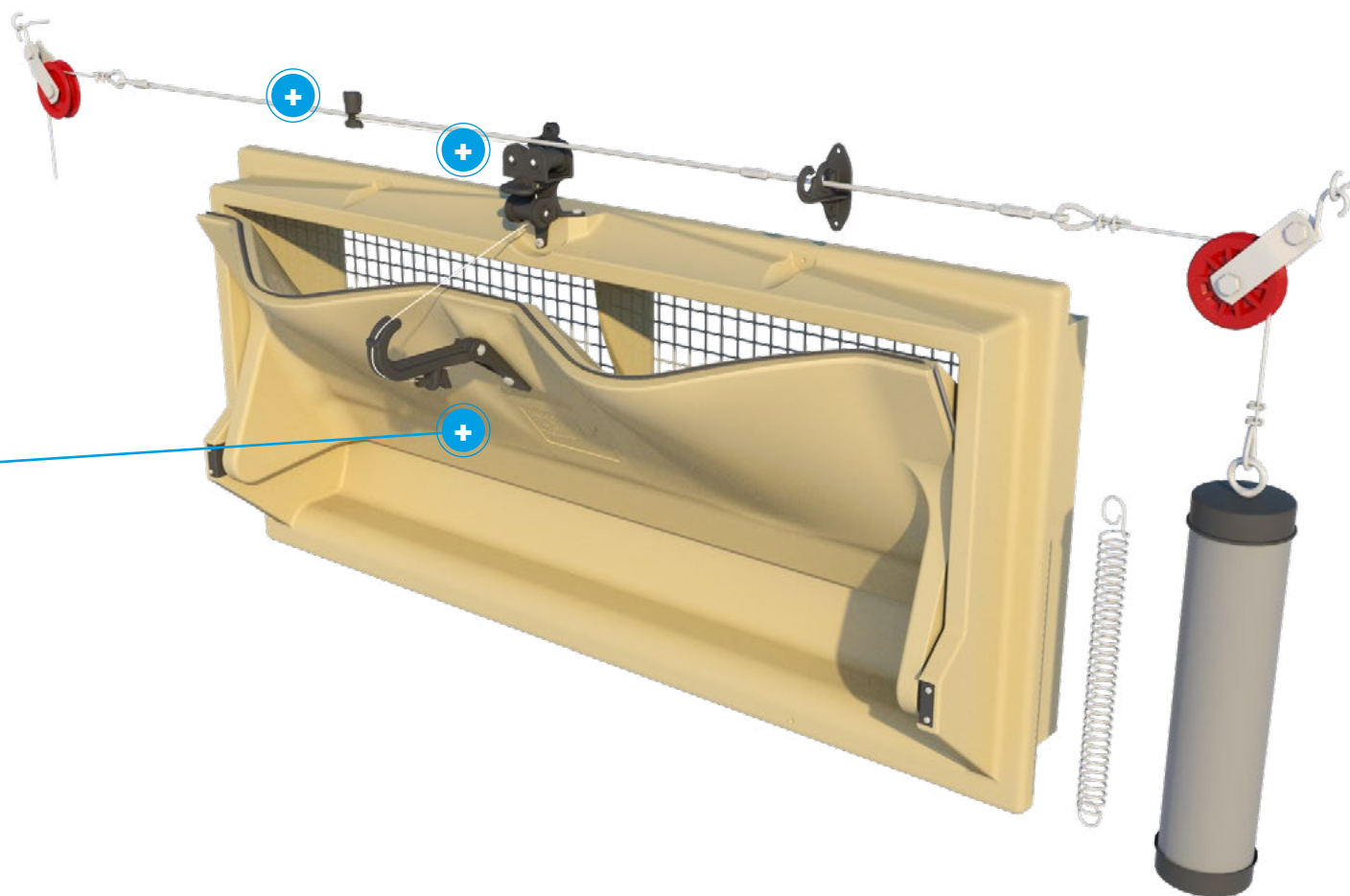

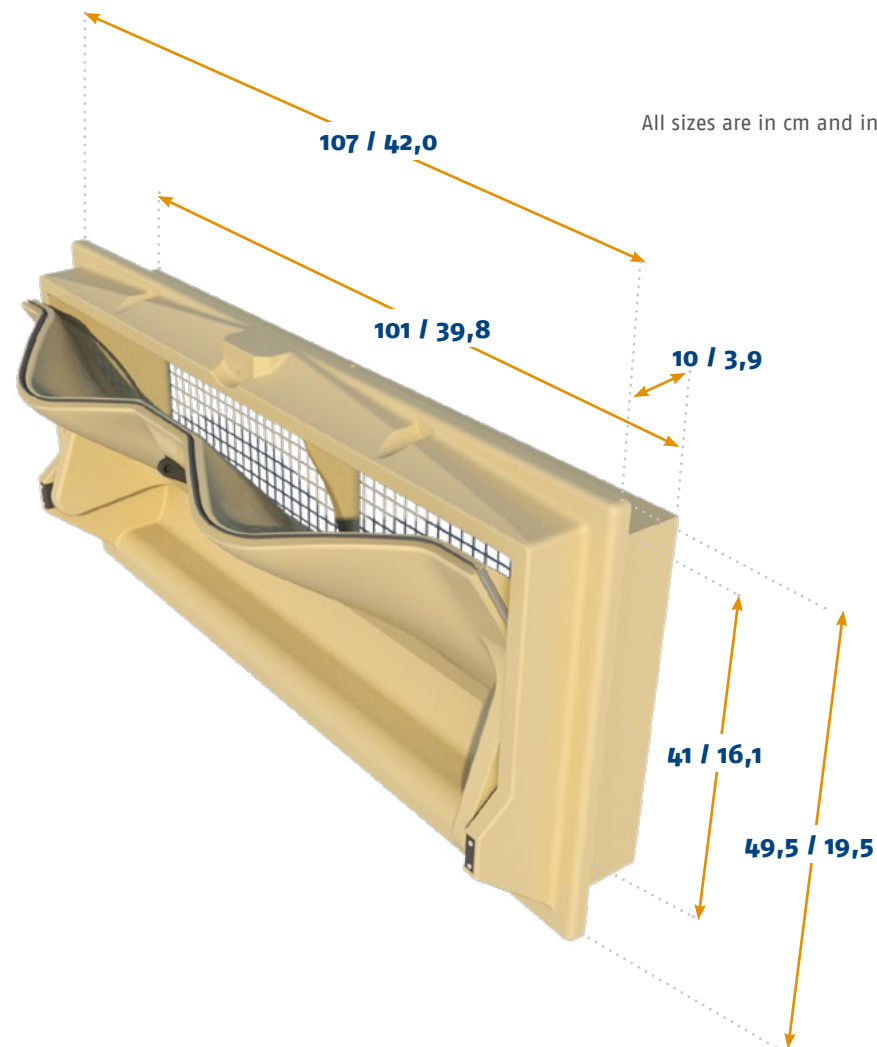
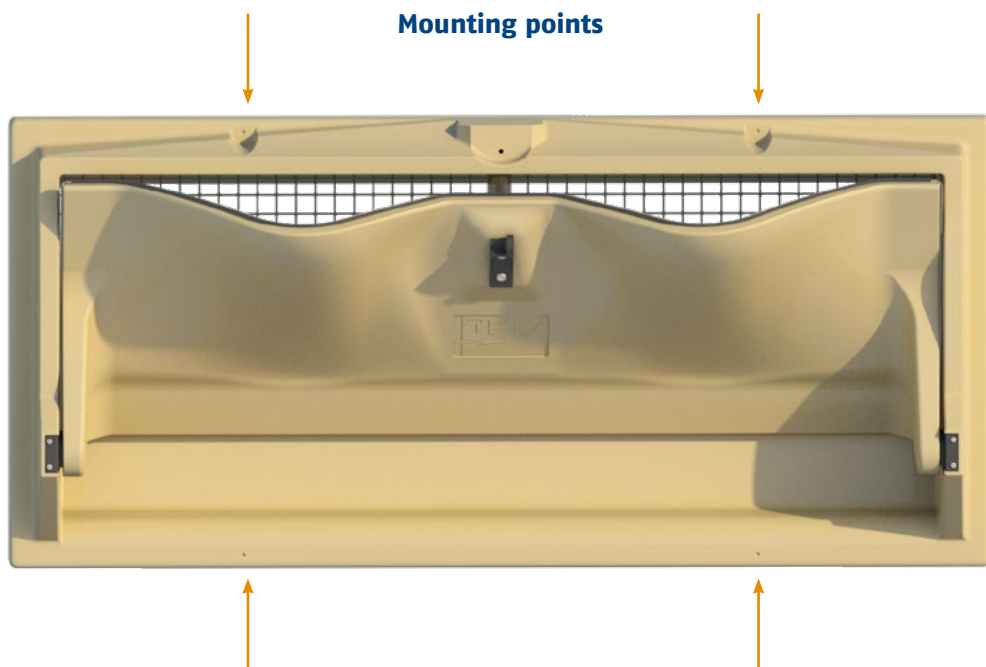

MOUNTING

Mounting type	Wall
Mounting hole size	103 cm / 40,6 inch x 43 cm / 16,9 inch

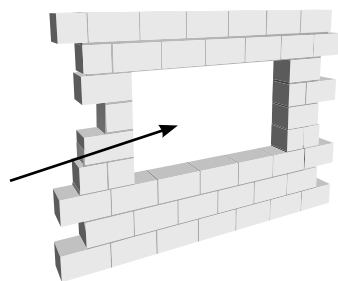

INFO

DATASHEET

ASSEMBLY

MOUNTING

WORKING

MAINTENANCE

AIR FLOW

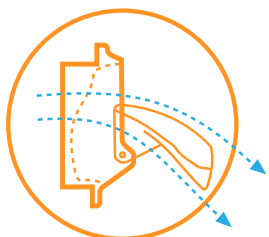
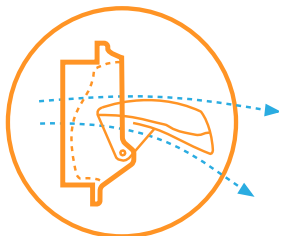
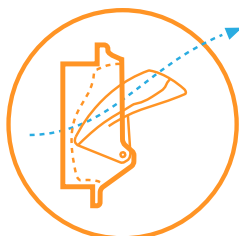

Opening and closing of inlets

Our standard inlets are spring-opened which means that without force on the main cable they will open automatically. The air inlets are connected to a main cable which can be pulled by a motor winch or actuator. In a normal situation, when pulling on the main cable the inlets are closing. The spring or end weight at the other end of the main cable makes sure the main cable is held straight and in place.

Self-closing inlets and delayed opening

A major part of our program can also be produced as a self-closing air inlet. In this scenario the opening and closing works the opposite way. The hanging pulleys have to be installed on the bottom flange and the central plastic control arm needs to guide the nylon cord downwards. The main cable has to be mounted underneath the inlets. With this set-up a system of delayed opening can be made, meaning that by adjusting the angle of the central control arm you can determine how early or late an inlet opens compared to another on the same line.

Making adjustments

By using the nylon bolt and nut small adjustments can be made to make sure all inlets are closing and opening correctly. The nylon cable clamp and cord can also be used to make small adjustments.

Working with springs or end-weights

At the opposite end on the main cable of where the motor winch or actuator is located there are two options to choose from: an end-weight which can be filled with concrete or sand, or a spring that holds tension on the cable.

Balanced set-up

When placing the motor winch or actuator we normally suggest to divide the inlets in two groups. It is often preferable to place the motor winch or actuator in the middle to equally split the forces that are exerted upon the inlets and winch.

Use of closing catches

The closing catch on the inlet can be used to permanently close inlets for example during pre-heating. The closing catches can also be used to close certain inlets while continuing to use others therefore offering the opportunity to open the inlets which are in use a bit further. In colder climates this can help to offer better resistance to freezing effects.

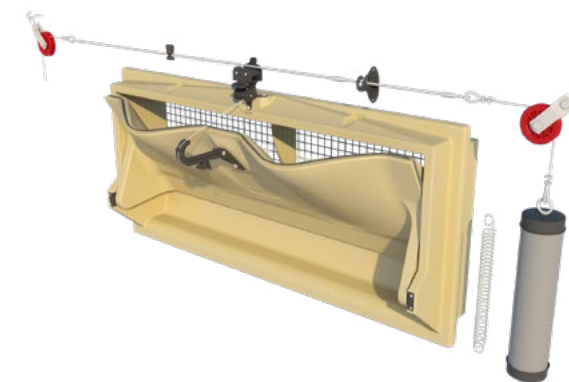

INFO

DATASHEET

ASSEMBLY

MOUNTING

WORKING

MAINTENANCE



WARRANTY / MAINTENANCE

WARRANTY

TPI-Polytechnik offers a 1 year warranty on manufacturers defects. This warranty covers any defects caused by faulty production or design flaws. For parts that are designed to move, wear and tear there is no warranty as these parts are intended and designed to be replaceable. To find details on which parts are marked as replaceable please contact TPI-Polytechnik for further information.

Since TPI-Polytechnik products are meant to be installed by professionals there is no warranty over installation mishaps or any damage caused by incorrect installation of the products herein. TPI-Polytechnik does offer a service warranty of 1 years over correctly and professionally installed products, therefore we strongly advise to use professional personnel.

Our polyurethane formula guarantees high insulation values but does not in any case guarantee that our products cannot freeze when in low temperatures. To ensure optimal functioning of your product(s) please contact your dealer or TPI-Polytechnik for information on installation, set-up adjustments and functionality.

Please note that under no circumstance TPI-Polytechnik is responsible for injuries or loss of life due to malfunction of our products!

INSTALLATION – SET-UP – MAINTENANCE

Make sure to mount inlets on a flat wall surface

A flat wall surface ensures optimal fitment and therefore air leakage will be reduced to a minimum. For optimal functioning make sure to caulk all sides of the inlet with a silicon sealant.

Layout Main Cable

In the layout, straight lines are recommended. Avoid additional pulleys. For additional information, please consult our support department.

Do not use foams or fillers to fill space in between the inlet and the wall

Foams and fillers might cause damage to the inlet or cause it to jam as they have different expansion values due to temperature differences. When in doubt, please ask your supplier for additional information.

Use screws with rivets for mounting the inlets into the wall, be aware of the polyurethane skin

With the use of rivets for mounting the inlets into the wall one can prevent the screw to sink into the flange or skin of the inlet. The outer skin of the polyurethane is hard but the force exerted on screws during installation might penetrate the skin.

For the set-up, connect the inlet to the main cable when in closed position

Make sure the inlet is closed when connecting it to the main cable, this will ensure all inlets are connected in the same modus and less adjustments are needed to optimize the set-up.

Cleaning

Pay close attention while cleaning the inlets, avoid using corrosive cleaning solutions that might harm the polyurethane. Also make sure not to use too much pressure with the pressure washers as it might damage the skin of the inlets. Use max. 120 bar at a minimal distance of 10cm and temperatures not exceeding 40°C

[BACK](#)