

## 6000-VFG-2-C

This tunnel unit is built up out of two single 6000-VFG inlets. This version is equipped with a curved inner valve that guides the air upwards during minimum ventilation. After opening further than 35% the air will also flow underneath the inner valve. This unit is controlled by two central arms per valve, which in turn, are connected with the other inner valves.



**INFO**

**DATASHEET**

**ASSEMBLY**

**MOUNTING**

**WORKING**

**MAINTENANCE**



# 6000-VFG-2-C DATASHEET



## CAPACITY

Model	m <sup>3</sup> /h @ 10 Pa	m <sup>3</sup> /h @ 25 Pa	m <sup>3</sup> /h @ 40 Pa
6000-VFG-2-C	11600	17500	23200
	cfm @ 0.05 inH <sub>2</sub> O	cfm @ 0.1 inH <sub>2</sub> O	cfm @ 0.15 inH <sub>2</sub> O
	7633	11493	13186

## INFORMATION

Run	40 cm / 15.7 inch
Force	7 kg / 68.6 Newton
Number / pallet (1.65 x 0.95 x 2.40 m)	10
Weight / per inlet	21,3 kg / 47 lbs
Volume / per box	2
Arm position	3+

## OPTIONAL ACCESSORIES

TPI-107 (*2)	Wire mesh synthetic
TPI-208c	Connection set
TPI-307 (*4)	Closing catch + spring
TPI-519 (*2)	Main cable support

## AIR FLOW

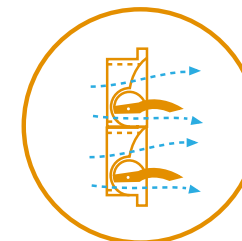
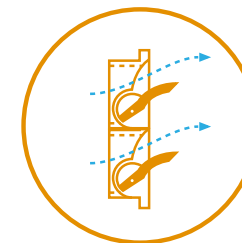

[INFO](#)

**[DATASHEET](#)**

[ASSEMBLY](#)

[MOUNTING](#)

[WORKING](#)

[MAINTENANCE](#)

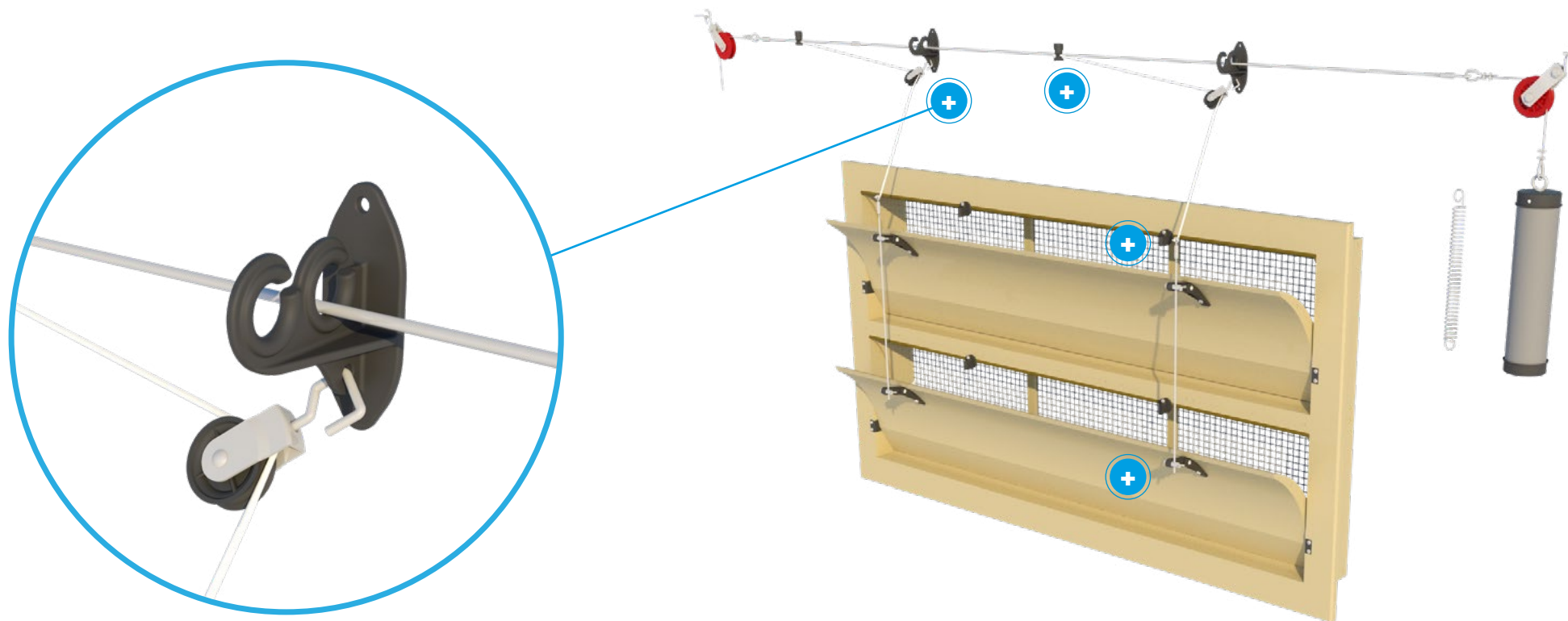

TPI-519

[INFO](#)

[DATASHEET](#)

[ASSEMBLY](#)

[MOUNTING](#)

[WORKING](#)

[MAINTENANCE](#)



TPI-208A

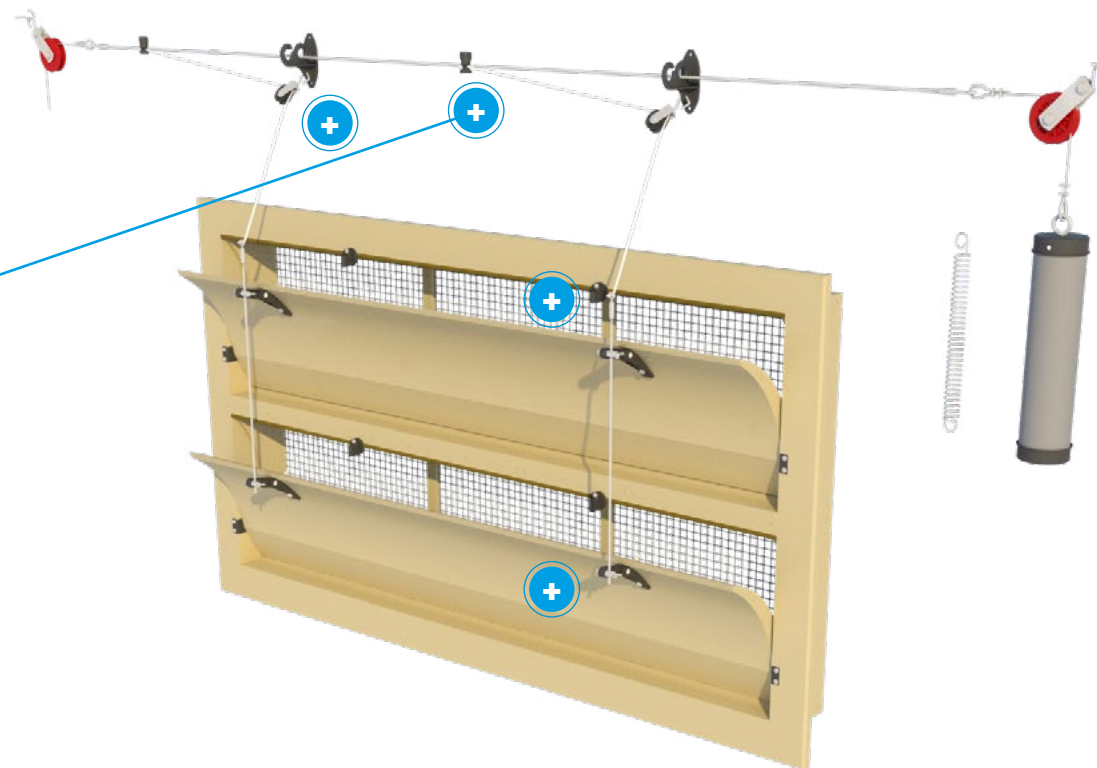

INFO

DATASHEET

ASSEMBLY

MOUNTING

WORKING

MAINTENANCE

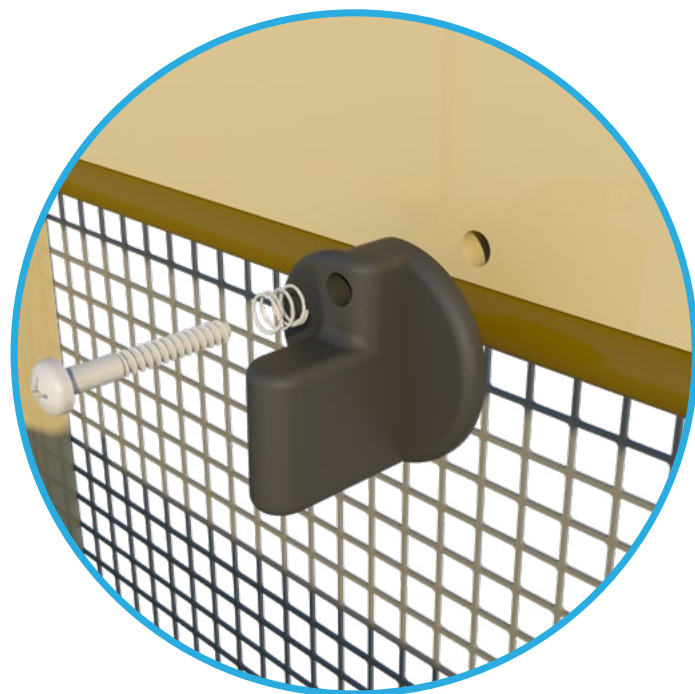

TPI-307

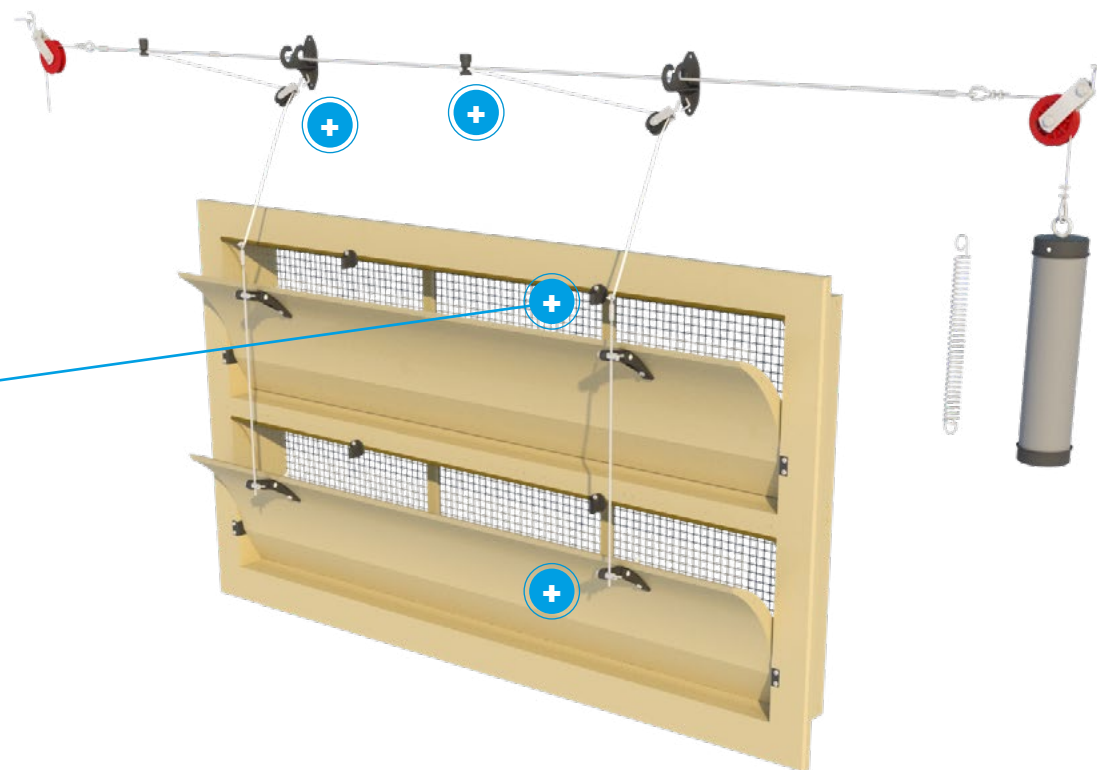

INFO

DATASHEET

ASSEMBLY

MOUNTING

WORKING

MAINTENANCE

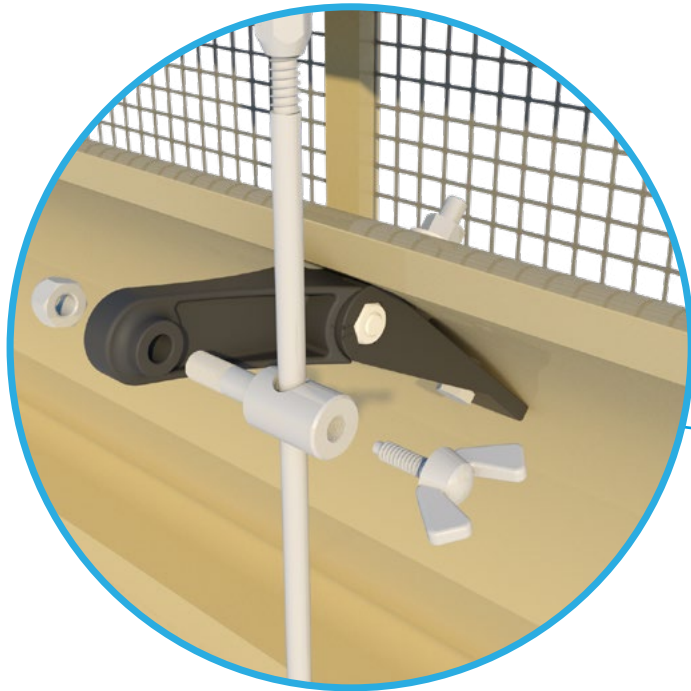

**TPI-208A**

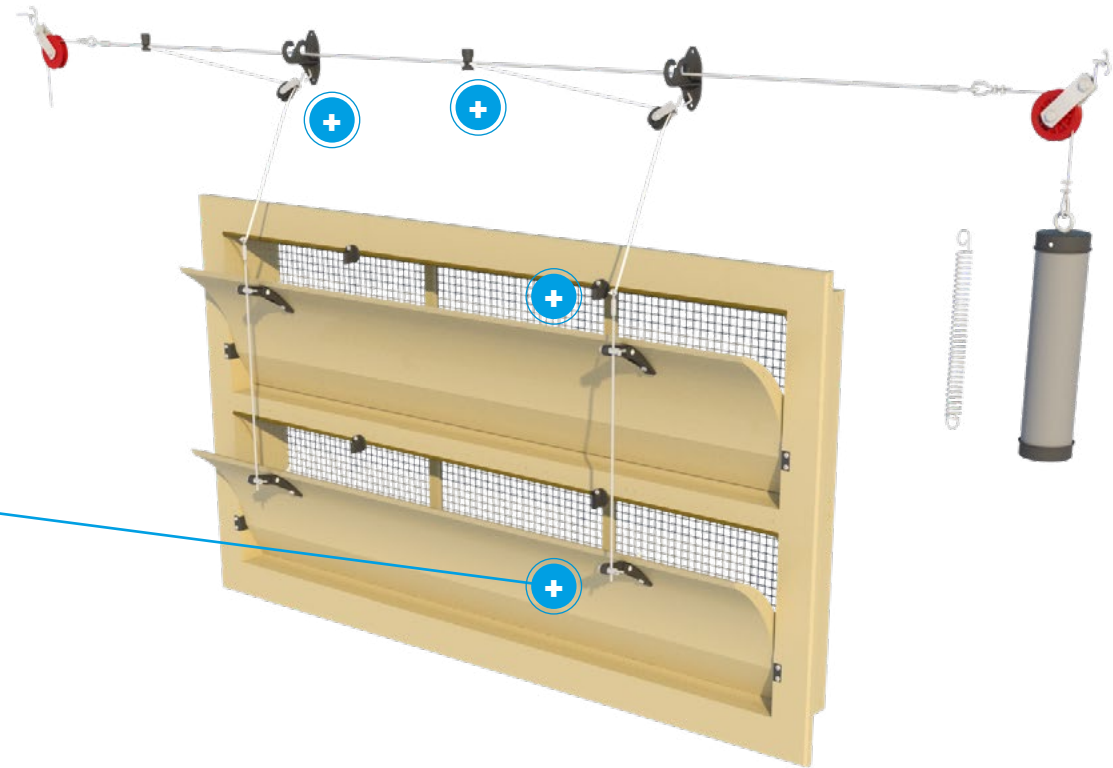

[INFO](#)

[DATASHEET](#)

[ASSEMBLY](#)

[MOUNTING](#)

[WORKING](#)

[MAINTENANCE](#)

All sizes are in cm and inches

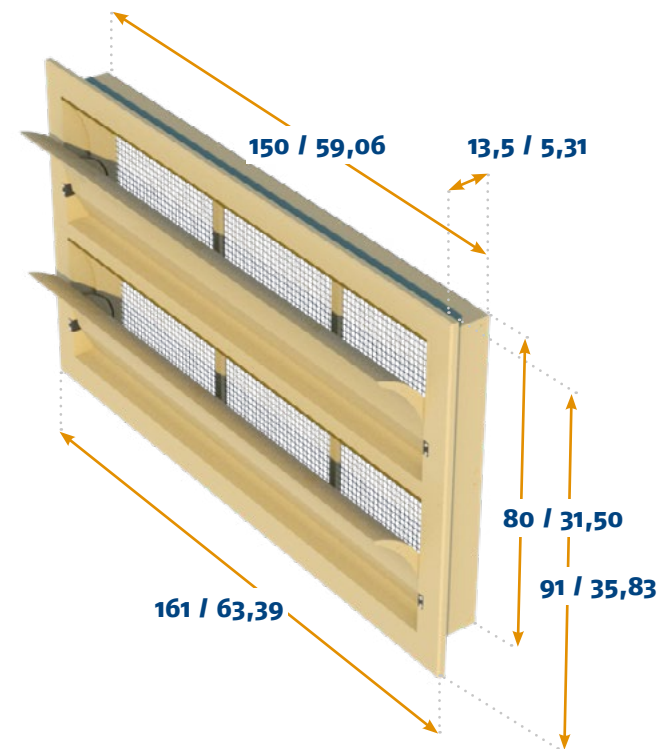
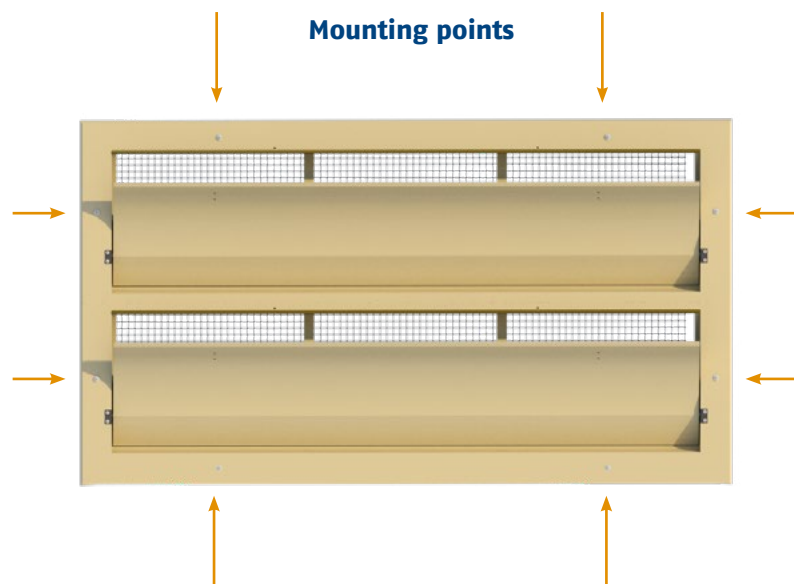

## MOUNTING

Mounting type	Wall
Mounting hole size	152 cm / 59,84 inch x 82 cm / 32,28 inch

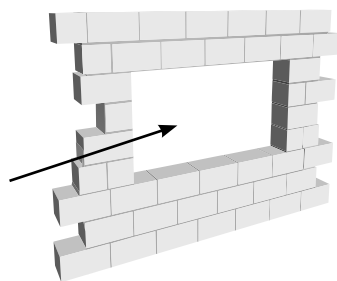

[INFO](#)

[DATASHEET](#)

[ASSEMBLY](#)

**[MOUNTING](#)**

[WORKING](#)

[MAINTENANCE](#)

## AIR FLOW

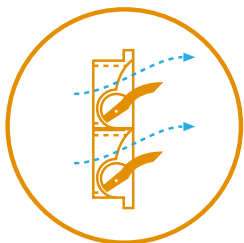

### Middle hinged inlet

This middle hinged inlet is made to allow air to also flow underneath the inner flap after opening further than 35%. This helps to guide air downwards to the animals and provide a cooling effect during maximum ventilation.

### Curved inner flap

This inlet is equipped with a curved inner flap. Curved flaps guide the air upwards during minimum ventilation, but also downwards after a certain point of opening. This is ideal for houses where air should be directed directly towards or over the animals during maximum ventilation.

### Working with end-weights or springs

We offer two products which can be used to keep tension on the main cable. A PVC cylinder which can be filled with concrete or sand to act as end-weight, or a spring that holds tension on the cable.

### Balanced set-up

When placing the motor winch or actuator we normally suggest to divide the inlets in two groups. It is preferable to place the winch or actuator in the middle to equally divide the forces on the main cable.

(see ventilation concepts page for an example)

### Use of closing catches

The closing catch on the inlet can be used to permanently close inlets for example during pre-heating. The closing catches can also be used to close certain inlets while continuing to use others. In that case the used inlets can be opened a bit further. In colder climates this can help to offer better resistance to freezing effects.

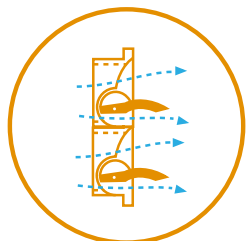
[INFO](#)
[DATASHEET](#)
[ASSEMBLY](#)
[MOUNTING](#)
[WORKING](#)
[MAINTENANCE](#)





# WARRANTY / MAINTENANCE

## WARRANTY

TPI-Polytechnik offers a 1 year warranty on manufacturers defects. This warranty covers any defects caused by faulty production or design flaws. For parts that are designed to move, wear and tear there is no warranty as these parts are intended and designed to be replaceable. To find details on which parts are marked as replaceable please contact TPI-Polytechnik for further information.

Since TPI-Polytechnik products are meant to be installed by professionals there is no warranty over installation mishaps or any damage caused by incorrect installation of the products herein. TPI-Polytechnik does offer a service warranty of 1 years over correctly and professionally installed products, therefore we strongly advise to use professional personnel.

Our polyurethane formula guarantees high insulation values but does not in any case guarantee that our products cannot freeze when in low temperatures. To ensure optimal functioning of your product(s) please contact your dealer or TPI-Polytechnik for information on installation, set-up adjustments and functionality.

Please note that under no circumstance TPI-Polytechnik is responsible for injuries or loss of life due to malfunction of our products!

## INSTALLATION – SET-UP – MAINTENANCE

### **Make sure to mount inlets on a flat wall surface**

A flat wall surface ensures optimal fitment and therefore air leakage will be reduced to a minimum. For optimal functioning make sure to caulk all sides of the inlet with a silicon sealant.

### **Layout Main Cable**

In the layout, straight lines are recommended. Avoid additional pulleys. For additional information, please consult our support department.

### **Do not use foams or fillers to fill space in between the inlet and the wall**

Foams and fillers might cause damage to the inlet or cause it to jam as they have different expansion values due to temperature differences. When in doubt, please ask your supplier for additional information.

### **Use screws with rivets for mounting the inlets into the wall, be aware of the polyurethane skin**

With the use of rivets for mounting the inlets into the wall one can prevent the screw to sink into the flange or skin of the inlet. The outer skin of the polyurethane is hard but the force exerted on screws during installation might penetrate the skin.

### **For the set-up, connect the inlet to the main cable when in closed position**

Make sure the inlet is closed when connecting it to the main cable, this will ensure all inlets are connected in the same modus and less adjustments are needed to optimize the set-up.

### **Cleaning**

Pay close attention while cleaning the inlets, avoid using corrosive cleaning solutions that might harm the polyurethane. Also make sure not to use too much pressure with the pressure washers as it might damage the skin of the inlets. Use max. 120 bar at a minimal distance of 10cm and temperatures not exceeding 40°C

[BACK](#)