

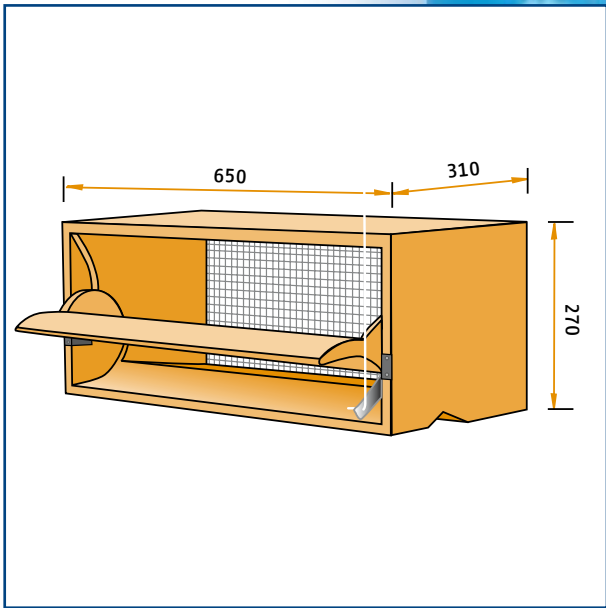

Capacity in m³/hour at static pressure of:

MODEL	10Pa	20Pa	40Pa
145-EG	1450	2050	2900



Model 145-EG

Air inlet valve made of high quality polyurethane foam. Build-in model for double wall systems; Depth 310 mm. Divided airdirections: upto 35% air enters only from the upper side; above 35% also from the bottomsides. Also available with straight inner flap (145-ER). As the valve is placed directly in the wall, it is executed with reinforcement profiles.

De Waterman 4
5215 MX 's-Hertogenbosch, Holland
P.O. Box 2064
5260 CB Vught, Holland
Phone: +31 (0)73-656 91 94
Fax: +31 (0)73-656 69 33

